

DL1608

Nearly 25 years ago, Mackie revolutionized the pro audio world by unleashing the CR1604 16-channel mixer. Today, Mackie redefines live mixing by combining the power of a digital mixer with the ease and portability of an iPad. Think of it as today's CR1604...but digital and unplugged.

CONTROL THE MIX FROM ANYWHERE:

With the Mackie DL1608's seamless wired to wireless mixing capabilities, you can mix in real time from anywhere in the venue on your iPad¹. The bar, the bathroom, the back closet. Instantly adjust mix functions from tuning front of house trouble spots to ringing out stage monitors.

CONTROL THE MIX FROM YOUR IPAD:

Designed specifically for the iPad, the DL1608's Master Fader app brings ground-breaking DAW mixing features and functionality to the live environment. With this intuitive breakthrough app, you can create mix snapshots, channel presets and even record stereo tracks straight to your iPad. Plus, with "Grow and Glow" giving you visual indication of the function you're controlling, you can be confident that you're always in control.

PROVEN HARDWARE THAT SOUNDS GREAT:

By combining 16 of our flagship Onyx mic preamps with the performance of 24-bit Cirrus Logic AD/DA converters, the Mackie DL1608 delivers unparalleled sound quality. Add to that eight balanced outputs, and you have a mixer that not only provides incredible dynamic range, fidelity and transparency, but also great versatility and outstanding value.

TONS OF BUILT-IN PROCESSING:

The DL1608 is loaded with a choice of powerful plug-ins on every channel, so you won't need to set up additional racks of outboard gear. With just the touch of a finger, you have total control over 4-band EQ, compression and gate plug-ins. Plus, sweeten your sound with a full-featured reverb and tap delay or adjust your mix to the room with the 31-band graphic EQ and limiter on the main and aux outs.

MULTIPLE IPAD SUPPORT:

Supporting up to 10 iPad devices simultaneously, the Mackie DL1608 allows multiple engineers to control the mix. Plus, it gives band members the ability to adjust their own monitors. We're looking at you, lead guitarist. Now, the band can dial in the mix they want to hear in real time right on stage.

FORWARD LOOKING DESIGN:

The sleek and low profile 16-channel Mackie DL1608 is rooted in design innovation. Its powerfully small format destroys the industry's notion that "bigger is better" by allowing modern technology to eliminate the need for bulky boards and racks of gear.



FEATURES:

- Proven hardware that sounds great
 - 16 Onyx mic preamps
 - High-end Cirrus Logic® converters
 - Ultra low-noise, high-headroom design
 - Six aux sends for monitor mixes
 - Master L/R output for mains
- Tons of built-in processing
 - Powerful, touch-sensitive plug-ins
 - 4-band EQ, gate and compression on inputs
 - 31-band GEQ and comp/limiter on outputs
 - Global reverb and delay
- Wireless mixing¹
 - Seamless wired to wireless mixing
 - Tune the room from anywhere
 - Get on stage to ring out monitors
 - Personal monitor mixing
 - Use up to 10 iPad devices simultaneously
- Total control from your iPad
 - Intuitive Master Fader app
 - "Grow & Glow" visual feedback
 - Preset and snapshot recall
 - Record the mix to the iPad for instant sharing
 - Integrate music from any app into the mix²
- Install friendly features
 - PadLock™ feature locks down iPad for permanent installs
 - Industry standard Kensington lock secures mixer
 - Compact footprint saves precious workspace
 - 15.5" x 11.5" x 3.9" (394 mm x 292 mm x 99 mm)
 - 7.9 lb (3.6 kg)

1 Wi-Fi router required for wireless operation. Wi-Fi router and iPad not included.

2 iPad must be docked and the app must support background audio playback.



DL1608 SPECIFICATIONS

General Digital

Sample Rate:	48 kHz
A/D/A Bit Depth:	24-bit
System Latency:	1.5 ms

Frequency Response

All inputs to all outputs:	±0, -1 dB, 20 Hz to 20 kHz
----------------------------	----------------------------

Distortion (THD)

Mic input to main output, 1 kHz, -1 dBFS:	<0.005%
-------------------------------------------	---------

Noise / Dynamic Range / Signal-to-Noise Ratio

Equivalent Input Noise (EIN)	
150 Ω termination:	-128 dBu
Mic input to main output (A-weighted)	
Channel and main faders at unity:	-79 dBu
Faders down:	-90 dBu
Crosstalk	
Adjacent inputs:	<-120 dB @ 1 kHz
Outputs:	<-105 dB @ 1 kHz
Phones level pot feedthrough @ minimum travel:	<-75 dB
Signal-to-Noise Ratio	
(ref +4 dBu, one channel and main fader at unity, A-weighted):	92 dB
Dynamic Range	
(One channel and main fader at unity, A-weighted):	109 dB
CMRR:	>70 dB @ 1 kHz (60 dB gain)

Analog Inputs 1-16

Connectors	
1-12:	XLR Balanced
13-16:	Combo XLR / TRS Balanced
XLR Mic Pre:	Onyx
Input Impedance	
1-12:	3 kΩ
13-16:	3 kΩ mic [XLR] 30 kΩ line [1/4"]
Max Input Level	
XLR:	+21 dBu
1/4":	+30 dBu
Gain	
XLR:	0 to 60 dB
1/4":	-20 to 40 dB
48V Phantom Power (XLR):	48 VDC, 10 mA max per mic, with up to eight simultaneously. 5 mA max per mic, with up to 16 simultaneously.

Analog Main Out L/R

Connectors:	XLR Balanced
Output Impedance:	600 Ω
Max Output Level:	+21 dBu

Analog Aux Sends 1-6

Connectors:	1/4" TRS Impedance Balanced (Supports balanced / unbalanced operation)
Output Impedance:	240 Ω Balanced 120 Ω Unbalanced
Max Output Level:	+21 dBu

Analog Headphone Out

Connector:	1/4" TRS Stereo
Max Output Level:	+18 dBu into 600 Ω +19.5 dBu max into 100 Ω

Networking

Connector:	100 MB Ethernet
Control:	Complete
Simultaneous Control:	10 iPad Devices

iPad Support

iOS Version Requirement:	5.1 or greater
iPad Version Requirement	
Wired:	Original iPad, iPad 2, iPad (3rd generation)
Wireless:	Original iPad, iPad 2, iPad (3rd generation), iPad (4th generation), iPad mini
Control Application:	Mackie Master Fader App ¹

¹ <https://itunes.apple.com/us/app/mackie-master-fader/id511500747?mt=8>



DL1608

Digital Live Sound Mixer with iPad® Control

DL1608 SPECIFICATIONS CONTINUED...

DSP

Input Channel Processing [1-16]:	HPF, EQ, Comp, Gate
Output Channel Processing [LR, A1-A6]:	GEQ, Comp/Limiter
FX:	Reverb, Delay

Power

Power Consumption:	48 watts max
External Supply	
Power Requirements:	100 VAC – 240 VAC, 50 – 60 Hz Universal Supply
Output Voltage:	12 VDC
Current:	4A
DC Connector:	5.5 mm x 2.5 mm barrel with locking ring
Line Cord:	User-replaceable IEC
Operating Temperature	0 - 40 °C
[extended ambient temperature]:	32 - 104 °F

Physical Properties (packaged product)

Height:	6.1 in / 155 mm
Depth:	18.9 in / 480 mm
Width:	18.1 in / 460 mm
Weight:	12.8 lb / 5.8 kg

Physical Properties (product)

Height (Front):	1.6 in / 40 mm
Height (Rear):	3.7 in / 95 mm
Depth:	15.4 in / 391 mm
Width:	11.5 in / 291 mm
Weight:	7.9 lb / 3.6 kg
Rack:	Nine Rack Spaces [Needs an additional space or two above to allow for connections]

Options

DL1608 Rackmount Kit:	P/N 2036840
DL1608 Mixer Bag:	P/N 2036809-16
DL1608 Mixer Cover:	P/N 2036809-17

Ordering Information

DL1608 Digital Live Sound Mixer with iPad Control, US:	P/N 2037372-00
DL1608 Digital Live Sound Mixer with iPad Control, EU:	P/N 2037372-01

DL1608 DIMENSIONS
NOTES:

- 1. WEIGHT APPROX. 7.9 lb [3.6 kg].**
- 2. SHIPPING WEIGHT APPROX. 12.8 lb [5.8 kg].**

UNLESS OTHERWISE SPECIFIED, ALL DIMENSIONS ARE IN INCHES DUAL [MM] DIMENSIONS FOR REF ONLY

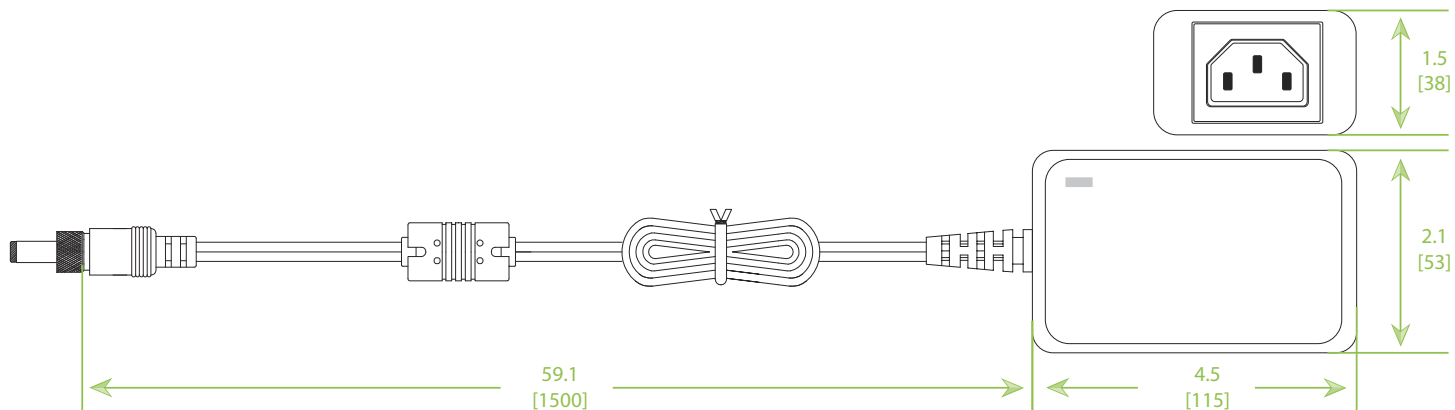
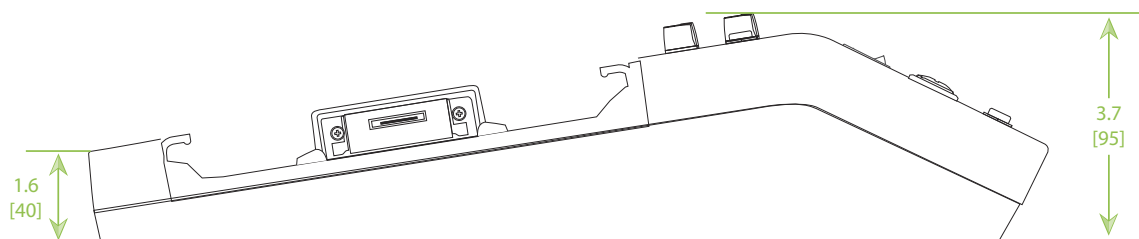
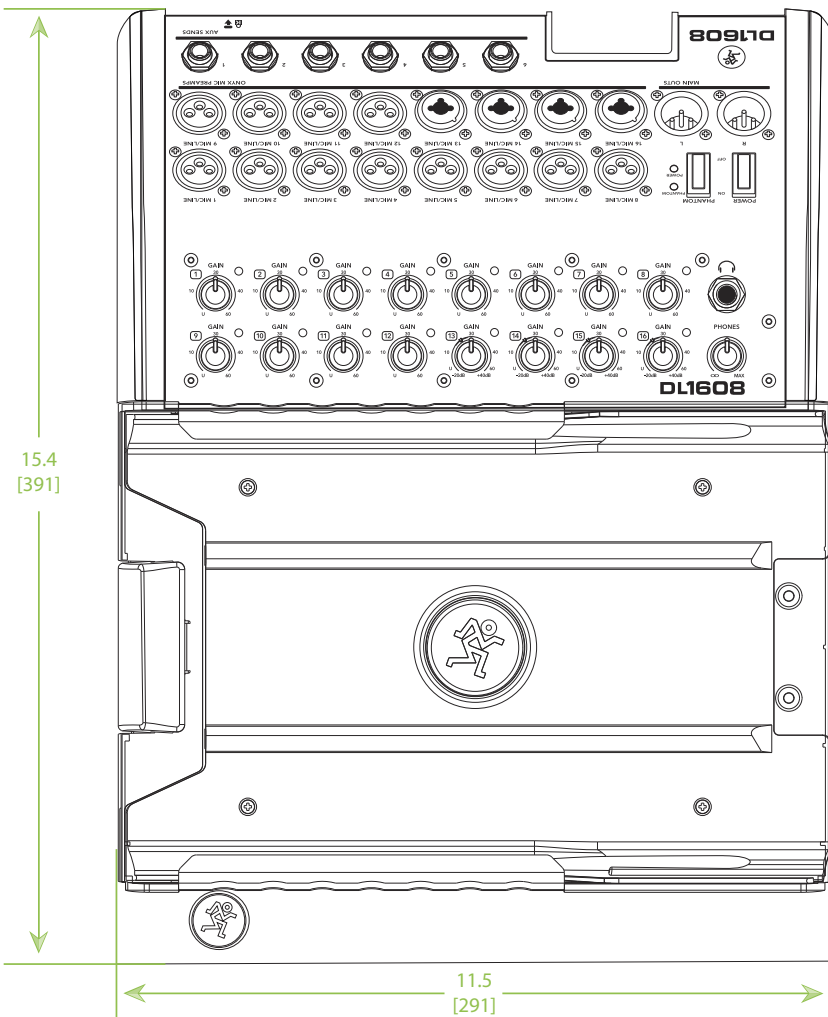

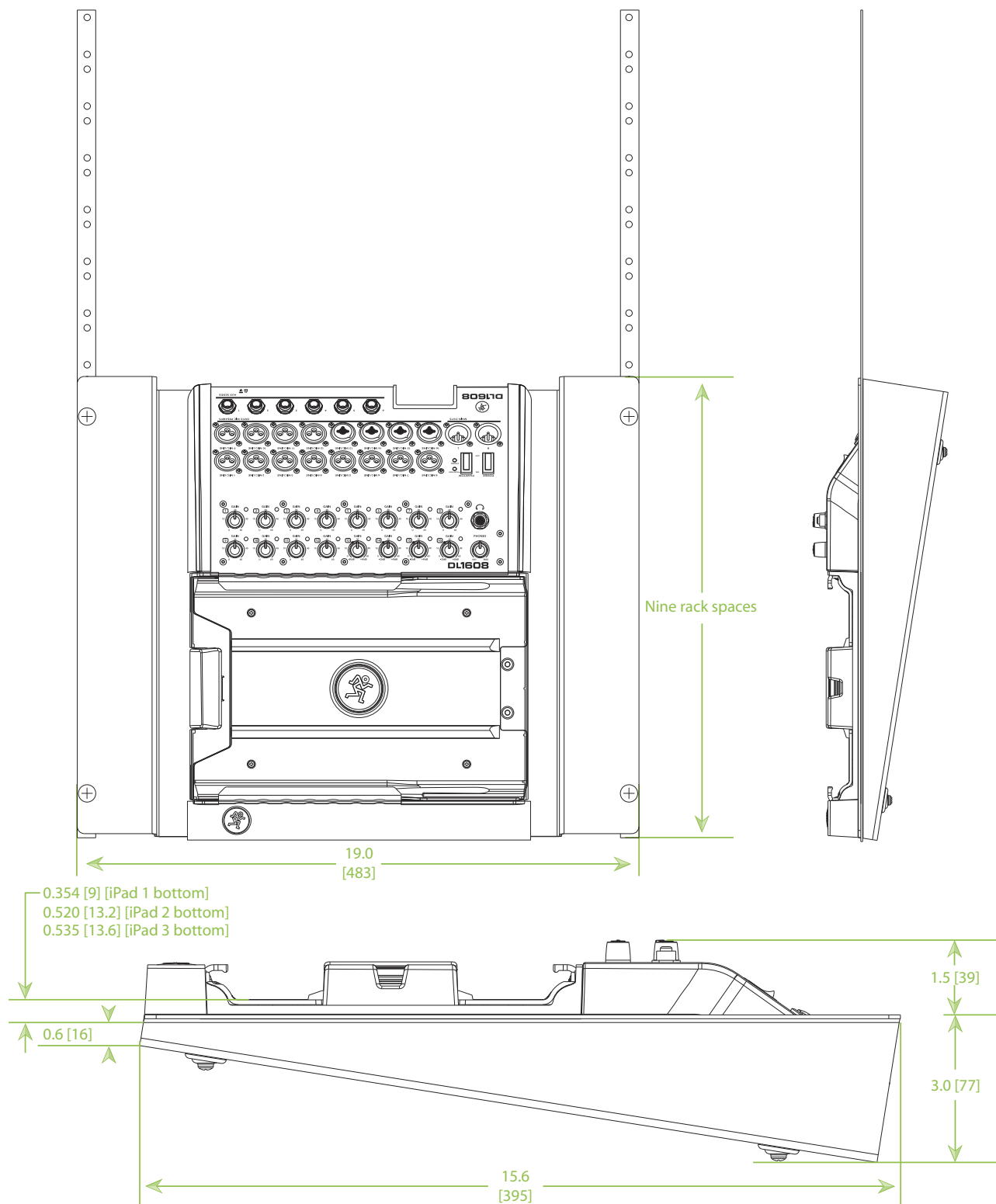
DL1608 DIMENSIONS CONTINUED...

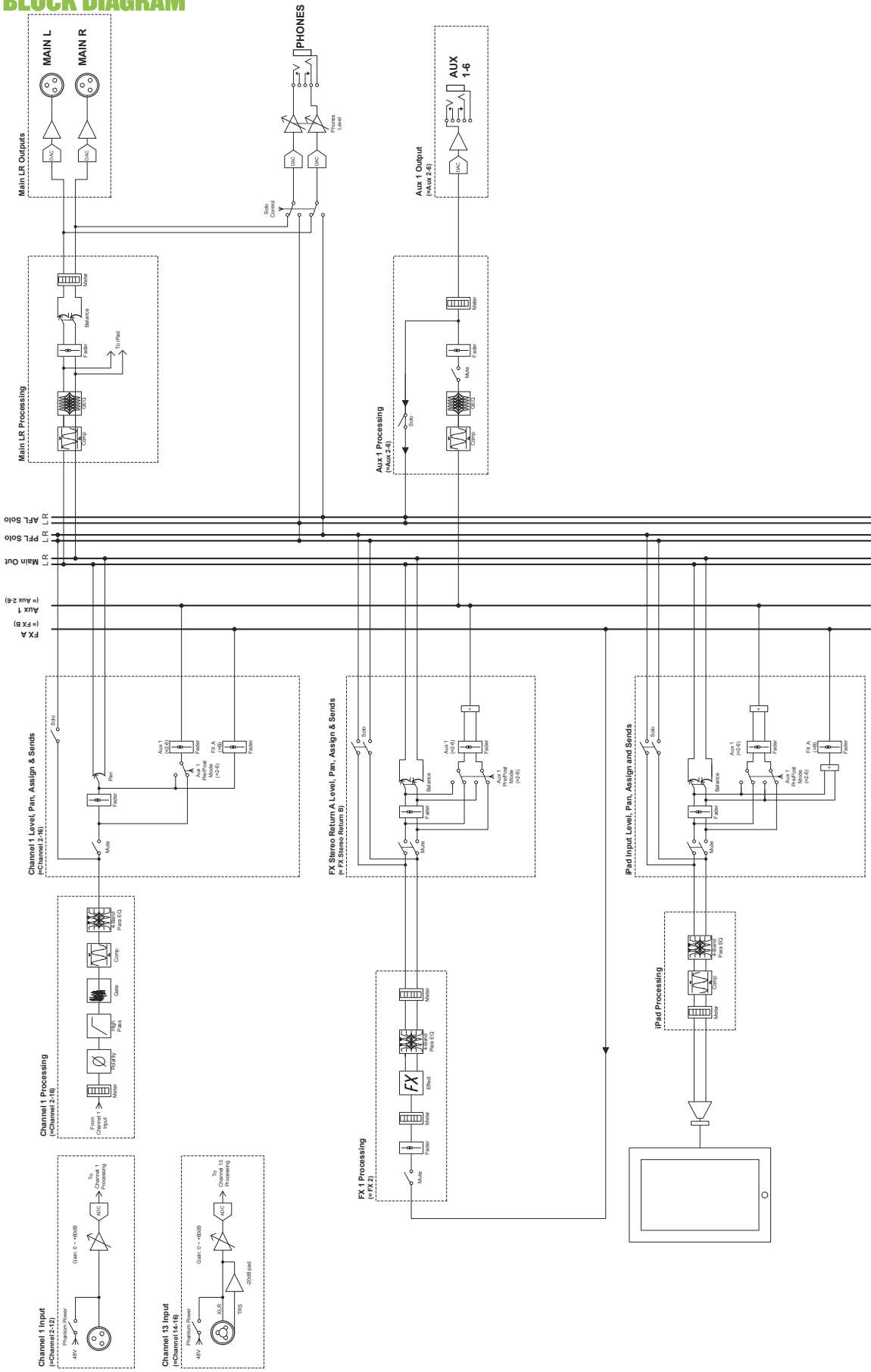
DLI608 BLOCK DIAGRAM

DL1608 FRONT PANEL

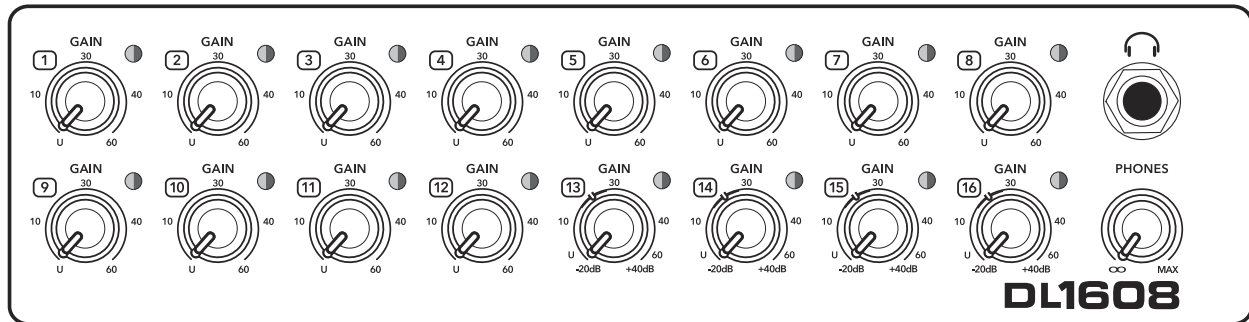

DL1608 REAR PANEL

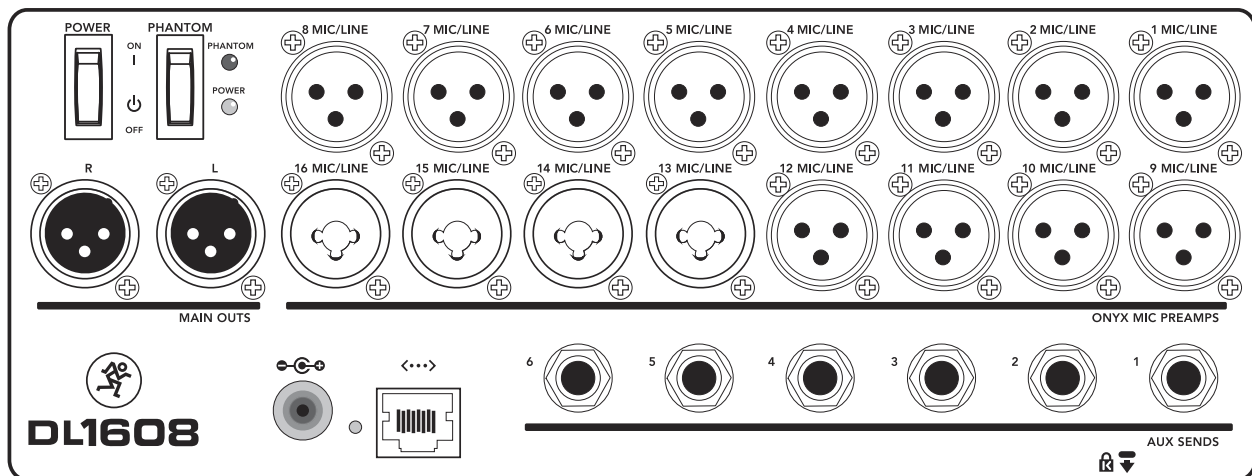

©2012 LOUD Technologies Inc. All rights reserved. Apple and iPad are trademarks of Apple, Inc., registered in the U.S. and other countries. All other marks are Registered Trademarks, or Trademarks, of LOUD Technologies in the United States and other countries. DL1608 Patent Pending.

“Made for iPad” means that an electronic accessory has been designed to connect specifically to iPad and has been certified by the developer to meet Apple performance standards. Apple is not responsible for the operation of this device or its compliance with safety and regulatory standards. Please note that the use of this accessory with iPad may affect wireless performance.

LOUD Technologies Inc. is always striving to improve our products by incorporating new and improved materials, components, and manufacturing methods. Therefore, we reserve the right to change these specifications at any time without notice.

Electronic files for this product are available at:

www.mackie.com

Specification Sheet	DL1608_SS.PDF
Reference Guide	DL1608_RG.PDF
Quick Start Guide	DL1608_QS.PDF



www.mackie.com
16220 Wood-Red Road NE
Woodinville, WA 98072 USA
800-898-3211, Fax 425-487-4337, sales@mackie.com

Part No. SW0953 Rev. A II/12